



INTERNATIONAL APPLICATION PUBLISHED UNDER THE PATENT COOPERATION TREATY (PCT)

<p>(51) International Patent Classification ⁶ : G01J 1/02, A61B 5/00, G01D 18/00</p>	<p>A1</p>	<p>(11) International Publication Number: WO 99/12008 (43) International Publication Date: 11 March 1999 (11.03.99)</p>
<p>(21) International Application Number: PCT/US98/17947 (22) International Filing Date: 27 August 1998 (27.08.98)</p> <p>(30) Priority Data: 60/057,903 4 September 1997 (04.09.97) US 09/138,824 24 August 1998 (24.08.98) US</p> <p>(71) Applicant: AVOCET MEDICAL, INC. [US/US]; 1696 Dell Avenue, Campbell, CA 95008 (US).</p> <p>(72) Inventors: ZWEIG, Stephen, E.; 16615 Ferris Avenue, Los Gatos, CA 95032 (US). MEYER, Benjamin, G.; 15020 Fruitvale Avenue, Saratoga, CA 95070 (US). DOWNEY, Thomas, D.; 10192 Peninsula Avenue, Cupertino, CA 95014 (US).</p> <p>(74) Agents: HESLIN, James, M. et al.; Townsend and Townsend and Crew LLP, 8th floor, Two Embarcadero Center, San Francisco, CA 94111-3834 (US).</p>		<p>(81) Designated States: AU, CA, JP, KR, European patent (AT, BE, CH, CY, DE, DK, ES, FI, FR, GB, GR, IE, IT, LU, MC, NL, PT, SE).</p> <p>Published With international search report.</p>

BEST AVAILABLE COPY

(54) Title: VERIFICATION DEVICE FOR OPTICAL CLINICAL ASSAY SYSTEMS

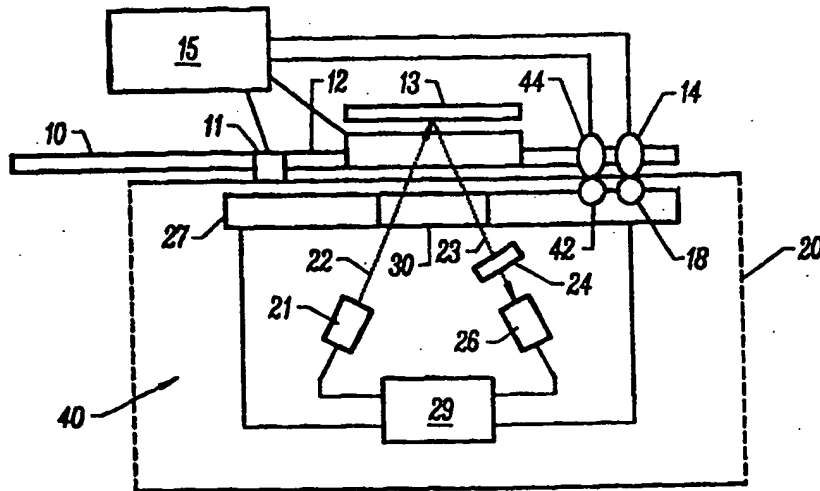

(57) Abstract

A device and method for verifying correct performance of an optical clinical assay system is provided. The device consists of a heated support stage (27), containing an optical window (30) through which light (22) emitted from a light source (21) can pass. Additionally, the device includes an optical shutter (12) with a backing (13) and a circuit board (10). An algorithm or method controls the rate in which an opaque optical reference is revealed to the detection apparatus and the algorithm or method is selected to simulate the reaction rates of one or more levels of clinical analytes reacting with a test reagent.

FOR THE PURPOSES OF INFORMATION ONLY

Codes used to identify States party to the PCT on the front pages of pamphlets publishing international applications under the PCT.

AL	Albania	ES	Spain	LS	Lesotho	SI	Slovenia
AM	Armenia	FI	Finland	LT	Lithuania	SK	Slovakia
AT	Austria	FR	France	LU	Luxembourg	SN	Senegal
AU	Australia	GA	Gabon	LV	Latvia	SZ	Swaziland
AZ	Azerbaijan	GB	United Kingdom	MC	Monaco	TD	Chad
BA	Bosnia and Herzegovina	GE	Georgia	MD	Republic of Moldova	TG	Togo
BB	Barbados	GH	Ghana	MG	Madagascar	TJ	Tajikistan
BE	Belgium	GN	Guinea	MK	The former Yugoslav Republic of Macedonia	TM	Turkmenistan
BF	Burkina Faso	GR	Greece	ML	Mali	TR	Turkey
BG	Bulgaria	HU	Hungary	MN	Mongolia	TT	Trinidad and Tobago
BJ	Benin	IE	Ireland	MR	Mauritania	UA	Ukraine
BR	Brazil	IL	Israel	MW	Malawi	UG	Uganda
BY	Belarus	IS	Iceland	MX	Mexico	US	United States of America
CA	Canada	IT	Italy	NE	Niger	UZ	Uzbekistan
CF	Central African Republic	JP	Japan	NL	Netherlands	VN	Viet Nam
CG	Congo	KE	Kenya	NO	Norway	YU	Yugoslavia
CH	Switzerland	KG	Kyrgyzstan	NZ	New Zealand	ZW	Zimbabwe
CI	Côte d'Ivoire	KP	Democratic People's Republic of Korea	PL	Poland		
CM	Cameroon	KR	Republic of Korea	PT	Portugal		
CN	China	KZ	Kazakstan	RO	Romania		
CU	Cuba	LC	Saint Lucia	RU	Russian Federation		
CZ	Czech Republic	LI	Liechtenstein	SD	Sudan		
DE	Germany	LK	Sri Lanka	SE	Sweden		
DK	Denmark	LR	Liberia	SG	Singapore		
EE	Estonia						

5

VERIFICATION DEVICE FOR OPTICAL CLINICAL ASSAY SYSTEMS

BACKGROUND OF THE INVENTION

10 Increasingly in modern clinical chemistry, whole
blood samples, often obtained by finger stick methods, are
analyzed using automated automatic analysis systems (meters)
which employ disposable (often one-time use) test elements,
and a non-disposable electronic test device that analyzes the
15 reaction occurring in the whole blood sample in the disposable
test element, and then outputs an answer. Such systems are
used for analyzing whole blood samples for glucose,
cholesterol, and increasingly, more complex tests such as
coagulation testing (prothrombin time, activated partial
thromboplastin time), enzymatic analytes, and the like.

20 Because the answer from these devices are often used
to make a clinical decision that can significantly impact the
health and well-being of a patient, verification methods to
insure that the analytical devices are performing correctly
are of obvious importance.

25 One common method for verifying correct performance
of a clinical analytical system is through the use of control
solution, which is usually a liquid chemical solution with
known reactivity. If the analytical device gives the correct
answer with a known reference chemical, then the overall
30 performance of the system can be assessed.

35 With modern one-shot, disposable test elements,
however, the problem with liquid control testing is that it is
destructive. The disposable test element has been destroyed
as a result of the testing, and only the now-validated meter
now survives to test the actual sample. For this reason,
modern verification methods tend to shift validation of
disposable test elements to manufacturers, who validate

batches of disposable test elements by statistical sampling methods. The problem of meter verification remains, however. Meters are typically used for years, and can be exposed to environmental extremes, misuse, and mechanical shock.

5 Because meter verification using liquid control devices and disposable test units is an expensive process, and because test unit verification is inherently best suited to statistical lot testing by the manufacturer, there is a need for low-cost methods that can verify the performance of the
10 meter without the use of liquid control solution and disposable test units.

 Analytical devices for temperature sensitive enzymatic analytes, such as blood coagulation, typically have a temperature controlled reaction stage, means to determine
15 the start of the enzymatic reaction, optical means to access the progress of the reaction, and computational means (typically a microprocessor or microcontroller) to interpret the progress of the reaction and output an answer. To completely verify the performance of the analysis system, each
20 subsystem must be assessed. The temperature controlled reaction stage must be tested for proper temperature control, the means to determine the start of the enzymatic reaction must be tested for proper sensitivity, the optical means to access reaction progress must be tested (light source, light
25 detector, integrity of optical stage, etc.), and finally the computational means must be tested. Alternatively partial verification of some of the subsystems may be done, and the remainder of the subsystems tested by alternate means, such as liquid control solution and a disposable test unit.

30 To verify the function of such analytical devices, electronic verification or "control" devices or circuits are commonly used. Such verification devices can simulate the action of an enzymatic sample interacting with a disposable reagent. If the analytical device returns the proper answer
35 after analysis of the verification device, then the proper functioning of the analytical device can be verified without the expense of using the one time use reagent cartridges.

The use of reference paint chips to calibrate and verify photometric devices has long been known in the art. When applied to home blood glucose monitors, such reference chips are often referred to as "check strips". For example, the LifeScan One-Touch™ blood glucose monitor includes a colorimetric "check strip" in with its meter system. This "check strip" consists of an opaque plastic strip with a paint chip of known colorimetric properties affixed to it. The check strip is inserted into the meter, and is used to verify the performance of the meter's colorimetric photodetector. The system does not vary the intensity of the colorimetric paint chip target as a function of time to simulate a normal test reaction, nor does it incorporate means to monitor the analytical devices' temperature.

Recent refinements to the basic "paint chip" technique, suitable for clinical reagents and instrumentation, include U.S. 4,509,959; 4,523,852; 4,729,657; 5,151,755; 5,284,770; and 5,592,290. U.S. 4,509,959 disclosed an apparatus incorporating many such reference color chips. U.S. 4,523,852 disclosed a reference standard, suitable for visually read diagnostic reagent test strips, consisting of many colored reference areas of differing hues. U.S. 4,729,657 disclosed photometer calibration methods using two or more reflectance standards and using least squares regression line analysis to construct and store calibration curves in the analytical device's memory. U.S. 5,151,755 disclosed methods to detect defects in biochemical analysis apparatuses measurement means by irradiating a reference density plate with light that has passed through a plurality of interference filters and comparing the relative amounts of reflected light obtained by these different measurements. U.S. 5,284,770 disclosed use of a check strip, along with an analytical instrument having a user insertable key (memory chip) containing the parameters of acceptable check strip performance, so that correct instrument performance can be automatically verified. U.S. 5,592,290 disclosed optical analyzer instrument error correction methods using standard color plates incorporating dyes with absorption spectrum

similar to the analytical reagent normally read by the analyzer. These standard color plates are then used in conjunction with a second reference optical analyzer and a specific correction algorithm to correct the instrument error in the first instrument.

In addition to passive "paint chip" verification methods, a number of different active (typically electronic) verification methods have also been used. These active verification methods typically involve electronic components, and often produce a dynamic (as opposed to a static) reference signal to the analytical instrument.

U.S. 4,454,752 disclosed a test circuit for use in a photometric coagulation instrument for plasma samples that verified the electronic circuitry of the instrument, wherein the rapid rise in clot density of a plasma sample may be simulated by a applying to the clot detection circuitry of the instrument a synthetic waveform that simulates the signal that results during clot formation in a reagent plasma mixture. However, this patent did not disclose methods by which the proper functioning of an instrument capable of measuring whole blood can be analyzed. The disclosed methods are capable of verifying only that the clot detection circuits of an photometric plasma coagulation instrument are performing properly. The patent did not disclose methods by which other instrument functions such as temperature control, absence of optical system light leaks, proper detection of sample insertion, etc., may also be verified.

Verification methods suitable for partially verifying the function of certain whole blood coagulation analyzers and unitized reagent cartridges are also known in the art. For example, U.S. 4,948,961 and 5,204,525 disclosed a quality control device for an instrument with an analysis cartridge constructed so that the instrument's light passes through the cartridge's internal chamber. Such systems have been used for a number of whole blood clinical tests, including whole blood prothrombin time assays when the internal chamber is filled with thromboplastin, and the

cessation of red cell movement is tracked by light scattering techniques.

U.S. 5,204,525 disclosed a control device using a liquid crystal cell interposed between the light source and detector in an analytical instrument, and a polarizing filter, so that the passage or block passage of light between the analytical device's light source and light detector when the voltage to the liquid crystal is modulated. However, neither U.S. 5,204,525 nor U.S. 4,948,961 disclosed means by which the temperature control of an analytical device may be verified. Although these publications disclosed devices useful for monitoring the function of optically transmissive reaction chambers in which the light source passes through the chamber, and which the reaction in question does not alter the wavelength of the light emitted by the instrument's light source, they did not disclose devices useful for monitoring the function of fluorescent test strip articles such as those disclosed in U.S. 5,418,143. In such systems, light of one wavelength enters a test strip, and excites a fluorescent compound which then emits light that exits the test strip at the same side as the light source (rather than passing through a reaction chamber), and at a different wavelength.

Another type of control device is found in the Boehringer Mannheim "Coaguchek" whole blood prothrombin time analysis device disclosed by U.S. 4,849,340. This device uses a disposable reagent cartridge consisting of a chamber with thromboplastin and magnetic particles. The disposable reagent cartridge is placed in a stage in the analysis device, and a blood sample is added. The analysis device subjects the reagent cartridge to a varying magnetic field, and detects the motion of the magnetic particles by the optical interaction between the motion of the magnetic particles and a beam of light. In normal operation, when blood is applied to the disposable reagent cartridge, the magnetic particles are free to move in suspension, and thus provide a high degree of modulation to the optical signal in response to the varying magnetic field. As the blood clots in response to the thromboplastin reagent, the magnetic particles become less

able to move, and thus provide a progressively smaller amount of modulation to the optical signal as time progresses.

An "electronic control" is provided for the Coaguchek. (Boehringer Mannheim electronic control user manual, 1996). This "electronic control" consists of a separate device consisting of a disposable reagent sized probe that fits in to the reagent stage on the Coaguchek device. The probe contains a magnetic coil pickup, a light emitting diode, and means to vary the intensity of the response of the light emitting diode to current generated by the magnetic coil pickup. By using this "electronic control" device, the operator can verify that the varying magnetic field generator on the Coaguchek is operating properly, and that the optical sensor on the Coaguchek is also operating properly. The temperature of the reaction stage, and the performance of the optical light source on the Coaguchek, are not tested by this device, however.

In addition to passive (time unvarying reference signal) and active (time varying reference signal) verification devices, a third type of verification methodology has been disclosed which incorporates certain verification systems on to the disposable reagent itself. This is disclosed by in U.S. 5,591,403 and 5,504,011. U.S. 5,591,403 disclosed a reaction chamber cuvette, useful for prothrombin time testing, with multiple conduits. One or more conduits contain the reaction chemistry for the prothrombin time reaction itself, and other conduits contain control agents useful for assessing certain functions of the analytical instrument that reads the test cartridge, and the test cartridge itself. Typically one "control" conduit will contain a vitamin K dependent clotting factor concentrate, and a different "control" conduit will contain an anticoagulant. In a properly functioning instrument, the control conduit with the vitamin K dependent clotting factor concentrate will initiate a coagulation signal early, and the control conduit with the anticoagulant will initiate a coagulation signal late. This tests the proper function of those meter detector elements that read the status of the control conduits.

Because the control elements are incorporated into normal prothrombin time reaction cuvette, an independent, non-destructive, test of proper meter function is not possible with this system.

5 Thus, a need exists for an improved verification device. This need and others are addressed by the instant invention.

SUMMARY OF THE INVENTION

10 One aspect of the invention is a method for verifying the output of a system having a radiation source and a radiation detector, said method comprising positioning a reference surface to receive radiation from the radiation source and return radiation to the detector; and modulating at
15 least one of the radiation from the source and the radiation to the detector over time to emulate reflective or radiation characteristics of a chemical or biological reaction on the reference surface.

20 A further aspect of the invention is a method for verifying the output of a system having a radiation source and a radiation detector, said method comprising positioning a reference surface to receive radiation from the radiation source and return radiation to the detector; and modulating at
25 least one of the radiation from the source and the radiation to the detector over time in response to temperature changes. In some embodiments, the temperature changes are determined within the system. In further embodiments, the temperature changes are determined external to the system.

30 A further aspect of the invention is an apparatus for use in combination with an analyzer having a radiation source and a radiation detector, said apparatus comprising a reference surface which produces return radiation in response to receiving radiation from the source, and means disposed adjacent the radiation surface for modulating at least one of
35 radiation to the reference surface or radiation from the reference surface. In some embodiments the modulating means modulates the radiation over time to emulate reflective or radiation characteristics of a chemical or biological reaction

on the reference surface. In further embodiments the modulation means modulates the radiation in response to changes in temperature.

A further aspect of the invention is an electronically controlled optical reference device useful for the verification of a clinical analytical system having an optical detection apparatus, the reference device comprising, an opaque optical reference; an optical shutter; means for controlling the percent exposure of the optical reference to the optical detection apparatus; optionally, a means to monitor the temperature of a reaction stage of the clinical analytical system; and an algorithm or method that controls the rate at which the optical reference is selectively revealed to the optical detection apparatus, said algorithm or method being selected as to simulate the reaction rates of one or more levels of clinical analytes reacting with a test reagent.

A further aspect of the invention is a verification device useful for determining the proper function of an optical, temperature controlled analytical instrument, the device comprising an electronic optical shutter with an optically active backing, interposed between an optical signal emitted by the analytical instrument and an optical detector mounted on the analytical instrument; a temperature sensor, the sensor contacting a reaction stage on the analytical instrument; and verification device electrodes, the verification device electrodes making contact with electrodes on the reaction stage of the analytical instrument; wherein the action of the device is initiated by a resistance drop across the verification device electrodes, and wherein the optical transmission of the liquid crystal shutter is modulated as a function of time and of the temperature of the reaction stage, wherein a range of levels of enzymatic activity measured by the analytical instrument at various operating temperatures is simulated.

A further aspect of the invention is a verification device useful for determining the proper function of an optical, temperature controlled analytical instrument, the

device comprising an optical shutter-fluorescent backing assembly comprising an optical shutter having a fluorescent backing placed on one side of the optical shutter; the assembly being interposed between an optical signal emitted by the analytical instrument and an optical detector mounted on the analytical instrument; a thermocouple in contact with a reaction stage on the analytical instrument; and verification device electrodes, the verification device electrodes making contact with electrodes on the reaction stage of the analytical instrument; wherein the action of the device is initiated by a resistance drop across the device electrode, and wherein the fluorescence of the optical shutter-fluorescent backing assembly is modulated as a function of time and of the temperature of the reaction stage, wherein a range of levels of enzymatic activity measured by the analytical instrument at various operating temperatures is simulated.

A further aspect of the invention is an electronically controlled optical reference device, useful for the verification of an analytical instrument having an optical detection apparatus and using optically read reagent test strips, the device comprising an opaque optical reference, which simulates the optical characteristics of a reagent test strip after reaction with its intended clinical sample; an optical shutter; a means for controlling the percent exposure of the optical reference to the optical detection apparatus; and an algorithm or method that controls the rate at which the check strip is selectively revealed to the optical detection apparatus, said algorithm or method being selected as to mimic the reaction rates of one or more levels of clinical analytes reacting with a reagent test strip.

A further aspect of the invention is a method for verifying the correct performance of a clinical analytical system comprising an optical detection apparatus, the method comprising contacting the clinical analytical system with an electronically controlled optical reference device useful for the verification of clinical devices using optically read reagent test strips, the reference device comprising, an

opaque optical reference, which simulates the optical characteristics of a reagent test strip after reaction with its intended clinical sample; an optical shutter; means for controlling the percent exposure of the optical reference to the optical detection apparatus; optionally, a means to monitor the temperature of the clinical analytical system; and an algorithm or method that controls the rate at which the optical reference is selectively revealed to the optical device, said algorithm or method being selected so as to mimic the reaction rates of one or more levels of clinical analytes reacting with a reagent test strip; and analyzing the optical reference; wherein an expected result of analysis of the optical reference by the clinical analytical system is predictive of the correct performance of the clinical analytical system.

A further aspect of the invention is a method for verifying the temperature control of a clinical analytical system comprising an optical detection apparatus, the method comprising contacting the clinical analytical system with a verification device useful for determining the proper function of an optical, temperature controlled analytical instrument, the device comprising an electronic optical shutter with an optically active backing, interposed between an optical signal emitted by the analytical instrument and an optical detector mounted on the enzymatic analytical instrument; a temperature sensor, the sensor contacting a reaction chamber on the analytical instrument; and verification device electrodes, the verification device electrodes making contact with electrodes on the reaction chamber of the analytical instrument; wherein the action of the device is initiated by a resistance drop across the verification device electrodes, and wherein the optical transmission of the liquid crystal shutter is modulated as a function of time and of the temperature of the reaction chamber; wherein a range of levels of enzymatic activity measured by the analytical instrument at a range of operating temperatures is simulated, and analyzing the optical reference; wherein an expected result of analysis of the optical reference by the clinical analytical system is

predictive of the correct operating temperature of the reaction chamber of the clinical analytical system.

BRIEF DESCRIPTION OF THE DRAWINGS

5 Figure 1 is a diagram depicting an electronic strip emulator constructed according to the principles of this disclosure (outside the dotted box), interacting with an exemplary test device (inside the dotted box).

10 Figures 2A and 2B depict two types of optical shutters. The shutter in Figure 2A comprises a single shutter element, which can be gradually varied from non-transmissive to transmissive. The optical shutter in Figure 2B comprises numerous shutter "pixel" elements.

15 Figure 3 is a graph depicting the output from the electronic verification device when the analytical device (meter) is at a normal temperature (37 °C), and at an aberrant temperature (33 °C). Here, Level I mimics a prothrombin time reaction curve obtained from a test sample with a normal prothrombin time value, and Level II mimics the prothrombin
20 time reaction curve obtained from a test sample with an elevated prothrombin time value.

 Figure 4 depicts an example of a temperature correction algorithm altering the kinetics of fluorescence development in response to the time averaged temperature
25 readings from the electronic verification device. The temperature algorithm is selected to match the temperature response of a real reagent test strip.

DESCRIPTION OF THE PREFERRED EMBODIMENT

30 The present invention provides a method for verifying the output of a system having a radiation source and a radiation detector, said method comprising positioning a reference surface to receive radiation from the radiation source and return radiation to the detector; and modulating at
35 least one of the radiation from the source and the radiation to the detector over time to emulate reflective or radiation characteristics of a chemical or biological reaction on the reference surface. In some aspects of the invention, the

modulator may operate without the reference surface by selectively reflecting light.

The present invention also provides a method for verifying the output of a system having a radiation source and a radiation detector, said method comprising positioning a
5 reference surface to receive radiation from the radiation source and return radiation to the detector; and modulating at least one of the radiation from the source and the radiation to the detector over time in response to temperature changes.
10 In some embodiments, the temperature changes are determined within the system. In further embodiments, the temperature changes are determined external to the system.

The present invention also provides an apparatus for use in combination with an analyzer having a radiation source and a radiation detector, said apparatus comprising a
15 reference surface which produces return radiation in response to receiving radiation from the source, and means disposed adjacent the radiation surface for modulating at least one of radiation to the reference surface or radiation from the
20 reference surface. In some embodiments the modulating means modulates the radiation over time to emulate reflective or radiation characteristics of a chemical or biological reaction on the reference surface. In further embodiments the modulation means modulates the radiation in response to
25 changes in temperature.

The present invention also provides a verification device for a clinical analytical system or instrument. Such a device is also referred to herein as a test strip emulator, a control test simulator, and an electronically controlled
30 optical reference device. The verification device is typically an electronically controlled optical reference device useful for the verification of a clinical analytical system having an optical detection apparatus. The reference device comprised an opaque optical reference or "target", an
35 optical shutter, and means for controlling the percent exposure of the optical reference to the optical detection apparatus. The opaque optical reference preferably simulates a colorimetric, fluorescent, or luminescent reagent test

strip. Optionally, a means to monitor the temperature of a reaction stage of the clinical analytical system is included as part of the device. The device is preferably programed with an algorithm or comprises a method that controls the rate at which the optical reference is selectively revealed to the optical detection apparatus. Typically the selective revealing of the optical reference is done by exposing the optical reference to the optical detection apparatus over a specified time interval. The algorithm or method is selected so as to simulate the reaction rates of one or more levels of clinical analytes reacting with a test reagent. The algorithm or method can be modified to account for the temperature of a reaction stage or chamber in the analytical system.

In some embodiments of the invention, the device of comprises one or more first electrodes, wherein electrodes contact one or more second electrodes on a reaction stage of the clinical analytical system. The electrical resistance across the electrodes in the reference device is modulated to simulate the addition or removal of a disposable reagent test strip or cartridge or a liquid sample to the clinical analytical system.

The optical shutter of the device may be electronically operated. Exemplary shutters include but are not limited to a liquid crystal shutter, a magneto-optical shutter, a Faraday effect optical shutter, a thermochromic optical shutter, an electrochromic optical shutter, or a micro-mechanical optical shutter. The optical shutter may be divided into a plurality of independently or semi-independently controlled pixel elements, such that the optical shutter modulates the intensity of an optical signal by varying the optical state of the shutter pixels in a time dependent manner.

In some embodiments, the optical shutter comprises a fluorescent backing on one side of the optical shutter, and a first optical signal of a first wavelength passes through the optical shutter and interacts with the fluorescence backing, and a fluorescence signal of a second wavelength passes back through the optical shutter. In further embodiments, the

optical shutter comprises a colored backing on one side of the optical shutter, and a first optical signal consisting of a first spectrum of wavelengths passes through the optical shutter and interacts with the colored backing, and a second optical signal consisting of a subset of the first spectrum of wavelengths passes back through the optical shutter. The optical shutter may also comprise a luminescent backing on one side of the optical shutter, with the optical signal comprising a time increasing or time decreasing luminescence signal.

In a further feature of the invention, a thermocouple monitors the temperature of the reaction stage of the analytical device. The transparency of the optical shutter may be modulated as a function of time and of a thermocouple monitored temperature of the reaction stage, wherein a range of levels of enzymatic activity measured by the analytical system at various operating temperatures is simulated.

In some embodiments of the invention, the verification device provides a means to monitor a reagent present and/or blood present sensor on the clinical analytical device, wherein a stimulus to these sensors is provided to signal readiness of the meter for testing a clinical sample.

The instant invention also provides a verification device useful for determining the proper function of an optical, temperature controlled analytical instrument. Typically such a device will comprise an electronic optical shutter with an optically active backing, interposed between an optical signal emitted by the analytical instrument and an optical detector mounted on the analytical instrument; a temperature sensor, the sensor contacting a reaction stage on the analytical instrument; and verification device electrodes, the verification device electrodes making contact with electrodes on the reaction stage of the analytical instrument. The action of the device is preferably initiated by a resistance drop across the verification device electrodes. The optical transmission of the liquid crystal shutter is modulated as a function of time and of the temperature of the

reaction stage, wherein a range of levels of enzymatic activity measured by the analytical instrument at various operating temperatures is simulated. The reaction stage of the analytical device may be heated.

5 In some embodiments the device comprises an optical shutter-fluorescent backing assembly comprising an optical shutter having a fluorescent backing placed on one side of the optical shutter; the assembly being interposed between an optical signal emitted by the analytical instrument and an
10 optical detector mounted on the analytical instrument; a thermocouple in contact with a reaction stage on the analytical instrument; and verification device electrodes, the verification device electrodes making contact with electrodes on the reaction stage of the analytical instrument. The
15 action of the device is initiated by a resistance drop across the device electrode. The fluorescence of the optical shutter-fluorescent backing assembly is modulated as a function of time and of the temperature of the reaction stage, wherein a range of levels of enzymatic activity measured by
20 the analytical instrument at various operating temperatures is simulated. The reaction stage of the analytical device may be heated.

 The instant invention also provides an electronically controlled optical reference device, useful for
25 the verification of an analytical instrument having an optical detection apparatus and using optically read reagent test strips. The device comprises an opaque optical reference, which simulates the optical characteristics of a reagent test strip after reaction with its intended clinical sample; an
30 optical shutter; a means for controlling the percent exposure of the optical reference to the optical detection apparatus; and an algorithm or method that controls the rate at which the check strip is selectively revealed to the optical detection apparatus, said algorithm or method being selected as to mimic
35 the reaction rates of one or more levels of clinical analytes reacting with a reagent test strip. In a preferred embodiment, the reagent is thromboplastin.

The instant invention also provides a method for verifying the correct performance of a clinical analytical system comprising an optical detection apparatus using the devices of the instant invention. In a preferred embodiment, the clinical analytical system is contacted with an electronically controlled optical reference device useful for the verification of clinical devices using optically read reagent test strips. The reference device, for example, comprises an opaque optical reference, which simulates the optical characteristics of a reagent test strip after reaction with its intended clinical sample; an optical shutter; means for controlling the percent exposure of the optical reference to the optical detection apparatus; optionally, a means to monitor the temperature of the clinical analytical system; and an algorithm or method that controls the rate at which the optical reference is selectively revealed to the optical device, said algorithm or method being selected as to mimic the reaction rates of one or more levels of clinical analytes reacting with a reagent test strip. An expected result of analysis of the optical reference by the clinical analytical system is predictive of the correct performance of the clinical analytical system.

The instant invention also provides a method for verifying the temperature control of a clinical analytical system comprising an optical detection apparatus using the devices of the instant invention. In a preferred embodiment, the method comprises contacting the clinical analytical system with a verification device useful for determining the proper function of an optical, temperature controlled analytical instrument. For example, the device comprises an electronic optical shutter with an optically active backing, interposed between an optical signal emitted by the analytical instrument and an optical detector mounted on the enzymatic analytical instrument; a temperature sensor, the sensor contacting a reaction chamber on the analytical instrument; and verification device electrodes, the verification device electrodes making contact with electrodes on the reaction chamber of the analytical instrument. The action of the

device is initiated by a resistance drop across the verification device electrodes, and wherein the optical transmission of the liquid crystal shutter is modulated as a function of time and of the temperature of the reaction chamber, wherein a range of levels of enzymatic activity measured by the analytical instrument at a range of operating temperatures is simulated. An expected result of analysis of the optical reference by the clinical analytical system is predictive of the correct operating temperature of the reaction chamber of the clinical analytical system.

The verification device of the invention can be provided as a probe, suitable for insertion into the reaction chamber of a colorimetric, fluorescent, or chemiluminescent test analytical instrument, with an opaque colorimetric, fluorescent or luminescent target. The reflectance, fluorescence or luminescence of the target is modulated by an optical shutter. Typically the probe will additionally contain a temperature sensor, a clock, and means to modulate the optical exposure of the probes target area according to a preset algorithm. The preset algorithm is designed to mimic the response of a normal reagent with one or more levels of test analyte. The probe may optionally contain other elements designed to interact with and test other meter functional elements, such as a meters "reagent present" and "sample present" sensors.

The optical characteristics of the opaque optical target can vary depending upon the analytical device in question. In one embodiment, the target is optically reflective and/or optically colored, so as to effectively change the distribution of various wavelengths or light intensity of the target as a function of the state of the optical shutter. In a further embodiment, the target can be made of a fluorescent material, so that the fluorescent intensity of the light detected by the analytical system's detector varies as a function of the state of the optical shutter. In a third embodiment, the backing can be luminescent (for example, an electronic luminescent panel), so that the luminescence seen by the analytical system's luminescence

detector varies as a function of the state of the optical shutter. Although for brevity, this discussion will focus on fluorescent targets, it should be understood that the same principles would also apply to colorimetric or luminescent analytical systems as well.

5 A fluorescent target is typically composed of a fluorescent compound, with absorption and emission characteristics similar to that of the analytical devices normal fluorescent reagent. The compound will typically be incorporated into a rigid support matrix. This can be done by mixing the fluorescent target compound with a suitable support carrier, such as acrylic paint, epoxy, or the like. To maximize the optical signal-to-noise characteristics of the fluorescent target, sufficient quantities of fluorescent compound are added as to completely interact with the entire fluorescence optical excitation signal, rendering the target optically opaque. The fluorescent target shifts the wavelength of the excitation signal to a different wavelength, and the fluorescent signal emerges from the side of the target that is illuminated by the excitation wavelength.

10 Alternatively, if it is infeasible to make the target opaque using large amounts of fluorescent compound, the back of the target may be painted with an opaque backing. The characteristics of this opaque backing may be selected to maximize the signal-to-noise performance of the fluorescent target. If the optical cutoff efficiency of the fluorescent detector's filters to the fluorescence excitation wavelengths is high, the opaque backing could be selected to be of a shiny reflective material. Alternatively, if the optical cutoff efficiency of the fluorescent detector's filters to the fluorescence excitation wavelengths is lower, a non-reflective (black) opaque backing may be chosen to minimize back reflections of the incoming excitation wavelengths to the fluorescence detector.

25 In yet another embodiment, the target may be luminescent, and used in a chemiluminescence detecting analytical device that has an optical detector, but does not contain a light source. The light source for the luminescent

target may be provided by variety of conventional electrical lighting techniques.

The optical shutter may be a mechanical or electro-mechanical shutter, such as an iris as typically used to control exposure intensity in cameras, a series of louvers, or the like. Alternatively, the optical shutter may be an electro-optical shutter, such as a liquid crystal shutter, a magneto-optical electric shutter, Faraday effect optical shutter, thermochromic optical shutter, Electrochromic optical shutter, micro-mechanical optical shutter, or other such device. Some exemplary optical shutters suitable for the present invention are disclosed, for example, in U.S. 3,649,105; 4,556,289; 4,805,996; 4,818,080; 5,050,968; 5,455,083; 5,459,602; and 5,525,430.

The optical shutter may be composed of a single functional shutter element, or alternatively it may be composed of many smaller functional shutter elements, that collectively act to alter the optical characteristics of the shutter as a whole.

In an configuration, the shutter is mounted so that light illuminating the optical (fluorescent) target passes through the shutter. Fluorescent light re-emitted by the optical target may pass directly to the analytical device fluorescence detector, or optionally pass through the optical shutter on the way to the fluorescence detector. Alternatively, the optical shutter can be mounted to interact only with light emitted by the optical target. In still a further configuration, the optical shutter can interact with light both illuminating and emitted by the optical target.

The device may optionally contain means of monitoring the temperature of the probe near the target area, as well as means of modulating the fluorescence signal in response to the temperature of the target area. These means may be mechanical, such as a bimetallic strip mechanical temperature sensor device hooked up to a mechanical shutter, chemical, such as a temperature sensitive liquid crystal thermometer, or electronic, such as a thermistor,

thermocouple, or the like. In the preferred embodiment, the temperature sensor is electronic.

The means to modulate the target's fluorescence may be mechanical, such as a clockwork mechanism, cam, or the like. The means may be controlled by analog electrical circuits, such as simple analog timers or the like, or the means may be controlled by digital electrical circuits, such as microprocessors, microcontrollers, and the like. In the case of mechanical means, the algorithm encoding the state of the target's fluorescence as a function of time is encoded into the design of the mechanical timing elements. In the case of analog electrical circuits, the algorithm is encoded by properly selected time constants, and the like. In the preferred case of digital microprocessor controllers, the algorithm is encoded by a specific program that controls fluorescence as a function of time, and optionally temperature and other variables.

To fully validate the analytical system's performance over a variety of sample ranges, the algorithm will ideally simulate the reaction occurring when samples with different relative activity react with test reagents. The algorithm may switch from simulating one test level to a different test level either in response to user input, or automatically as the test algorithm runs through a preset series of validation tests.

The verification device's probe may optionally contain one or more additional elements that interact with and validate other aspects of the proper function of the analytical system. For example, the probe may test the function of systems that determine if a cartridge has been properly inserted, or systems that determine if sufficient sample has been added. In the case of optical strip insertion or sample addition schemes, the probe may contain additional light emitting or light blocking devices designed to interact with appropriate optical detectors on the instrument. Alternatively, in the case of electronic strip insertion or sample addition schemes, such as those disclosed in U.S. patents 5,344,754 and 5,554,531, and in Zweig et. al.,

Biomedical Instrumentation & Technology 30: 245-256 (1996), the probe may contain one or more electrodes that interact with corresponding electrode sensors on the analytical device, and provide appropriate inputs to simulate normal activity.

5 The verification device may be constructed as a stand-alone, independently powered unit. This may be manually inserted or removed by the user, or inserted or removed by automated equipment. Alternatively, the verification device may be constructed as an integral part of the analytical
10 device itself, and may share one or more elements (power supply, microprocessor time, memory, etc.) with the analytical device.

 A schematic diagram of the verification device of the instant invention interacting with a meter is depicted in
15 Figure 1. In this embodiment, the meter 40 consists of an electrically heated support stage 27, containing an optical window 30 through which light 22 emitted from light source 21 can pass. The meter additionally contains an optional
20 fluorescence filter 24 and a photodetector 26. In normal use, light 22 travels through the optics window 30 and illuminates a fluorescent reagent target. Fluorescent light 23 travels through filter 24 and after filtration illuminates
25 photodetector 26. The meter is controlled by a microprocessor 29, which initiates test timing in response to inputs from strip detect and sample detection electrodes 28. The verification device circuit board additionally contains
30 electrodes 14 that interacts with the strip detect and blood detect electrodes 28 on the meter's optics block 20. A thermocouple 11 performs an independent measurement of the temperature of the meter's heated optics block 27.
The verification device has an optical shutter 12, with a backing 13, and a circuit board 10. A microcontroller 15 is also provided.

 In a preferred embodiment, the verification device
35 has an 8x8 pixel liquid crystal optical shutter 12, with an active area of 0.375 x 0.375", and an exterior size of 0.5" x 0.6", made by Polytronics, Inc. This is placed on a 0.02" thick circuit board 10, with exterior dimensions of 0.75", and

length of 2". The exterior circuit board is made to the same size as a disposable test strip unit normally used in an Avocet Medical prothrombin time detector (see Zweig, et al., Biomedical Instrumentation & Technology 30, 245-256; Figs 3 and 4).

The optical shutter has a backing 13 consisting of Rhodamine 110 mixed with epoxy. The rhodamine 110 retains its normal fluorescence activity when mixed with the epoxy, and the epoxy provided a way to affix the Rhodamine 110 to the back of the optical shutter 12 in durable and permanent manner. The active elements on the circuit board are controlled by a Texas Instruments TSS400-S3 sensor signal processor 15, which is a combination microcontroller, liquid crystal display driver, and A/D converter. The TSS400 additionally contains 2K bytes of programmable EEPROM, which contained the algorithm needed to drive the system. When turned on (switches not shown), the verification device initially turns all 64 pixels of the 8x8 pixel optical shutter to the opaque mode. Electrodes 14 connecting to the strip present sensors 28 on the meter's optics block 20 are switched to conducting mode (resistance is lowered), to allow the Avocet Meter to detect that a test strip is inserted into the optics block. The meter then initiates a warm-up sequence.

In this preferred embodiment, upon reaching proper temperature, the meter then sends a signal via its sensor electrodes 28 to the verification device electrodes 14 informing the verification device that the meter is now warmed up. Alternatively, the meter can signal to the user that it is ready, and the user can manually transfer this information to the verification device by pressing an electrical switch on the verification device. After the verification device is informed that the meter is now ready to proceed, the device then reduces the resistance across a second set of electrodes 44, which interact with the blood present sensors 42 on the meter's optics block. Whereas this resistance drop is normally used to signal the application of blood to the reagent strip (see, for example, U.S. patent 5,344,754), in

the instant invention it is used to signal the meter to proceed even though no blood has actually been applied.

In this preferred embodiment, the microcontroller 15 on the verification device consults an algorithm, and selectively switches an increasingly larger number of pixels on the liquid crystal shutter 12 to transparent mode as a function of a number of variables, including time, the setting of the verification device (e.g. Level I or II control, etc.), and optionally the temperature of the meter's optics stage 27 as measured by temperature sensor 11. The meter optical system 20 observes the fluorescent backing 13 through the optical shutter 12, and observes a progressive increase in overall fluorescence as a function of time. Alternatively, the verification device can progressively alter the voltage applied to a single element optical shutter element (see Fig. 2A) so as to progressively increase the transparency of the single element shutter as a function of time and temperature.

Exemplary algorithms are as follows. The verification device contains one or more stored reaction profile algorithms that control the percent light transmission of the optical shutter as a function of time. A preferred Level I algorithm is:

Equation 1: % fluorescence (% pixels switched on) =
100*[0.01*Reaction time-.0.35]

Equation 2: % fluorescence (% pixels switched on) =
100*[0.02*Reaction time-0.9]

Equation 3: % fluorescence (% pixels switched on) =
100*[0.01*Reaction time-0.05]

In a preferred embodiment, every ten seconds (the frequency at which the meter took data) for 240 seconds (a typical test duration) the verification device computes all three equations, and chose the results based upon the rule:

If Equation 1 <0 , % fluorescence = 0;

If Equation 1 >0 and $<20\%$, % fluorescence = Equation 1

If Equation 1 $>20\%$ and Equation 2 $<80\%$, % fluorescence =
Equation 2

5 If Equation 2 $>80\%$ and Equation 3 $<100\%$, % fluorescence =
Equation 3

If Equation 3 $>100\%$, % fluorescence = 100%.

This produces an "S" shaped reaction profile, shown
10 in Fig. 3, similar to that of a normal prothrombin time (Level
I) sample. In contrast, an exemplary algorithm used for the
elevated prothrombin time (Level II) control is:

Equation 1, 2, and 3: % fluorescence (% pixels on) =
15 $100 * [0.007 * \text{Reaction time} - 0.6]$

The decision tree is the same as the Level I control
shown previously. This produces a delayed, lower slope,
linear curve more typical of that of a normal Level II sample
20 reaction.

A typical temperature verification algorithm is as
follows. To verify that the meter's optical stage is being
maintained at the proper temperature, the thermocouple on the
electronic verification device periodically (every second)
25 performs a temperature measurement. The results from each
temperature are converted into degrees C if necessary. The
degree of deviation of the measured temperature from the ideal
temperature is used as input into a temperature correction
algorithm. This temperature correction algorithm advances or
30 retards the schedule of pixel switching on the optical shutter
in such a way as to mimic the response of a normal test
strip-reagent reaction reacting at a deviant temperature. For
a prothrombin time reaction, previous work (Daka et al.,
Journal of Investigative Surgery 4: 279-290; 1991), has shown
35 that the optimal reaction temperature for a prothrombin time
test is at a reaction time minima, and deviations from this
ideal temperature, either positive or negative, prolong the
prothrombin time value.

In a normal reagent reaction, the effects of temperature are cumulative. That is, a reaction held at the proper temperature for 95% of the reaction will be only mildly affected if the temperature is slightly deviant during 5% of the reaction. For an exemplary prothrombin time reaction, the effects of non-ideal temperature (either positive or negative) is to slow down the reaction (the ideal temperature is at a reaction time minima). Our own work, as well as the work of Daka et. al., has shown that for the prothrombin time verification device discussed by example here, the effects of non-ideal temperatures on the prothrombin time reaction can be approximated by the equation:

Fluorescence (Time, Temp) = Fluorescence (Time - (a * (Temperature Deviation) ²),

where "a" is an experimentally determined coefficient (here taken to be 0.1) used to bring the validation device's temperature variation in line with those of an actual reagent test strip.

The verification device reaction profile, described by the Level I and II equations above, can be temperature compensated to match a normal reagent reaction profile, reacting at a deviant temperature, by subtracting a factor proportional to the time weighted temperature deviation average from the % fluorescence calculation at each relevant time point. This delays the onset of fluorescent development. Higher order polynomial fits, or other temperature compensation functions, can also be used for these purposes.

The meter's microcontroller takes a series of fluorescence readings as for a normal test strip, and interprets the result according to its normal test strip algorithm. Previous work (U.S. 4,418,141 and the Zweig et. al., supra), has shown that for the prothrombin time example illustrated here, the prothrombin time (PT) time correlates linearly with the time at which the normalized fluorescence reaction profile first exceeds 10% of its maximum value (Time 10%). Thus by shifting the time at which the verification

device reaction profile first exceeds 10% of its maximum value; the temperature compensation algorithm will cause a corresponding shift in the prothrombin time value reported by the meter after reading the verification device.

5 Fig. 3 depicts the verification devices' fluorescence profiles reacting according to the Level I and Level II algorithm at a simulated optimal temperature of 37 °C, and at an aberrant lower temperature. Fig. 4 shows graphically how the verification device's temperature
10 correction algorithm delays the initial onset of the fluorescent signal (Time 10%) for meters operating at aberrant temperatures.

 If the meter is working properly, the answer displayed will be within the expected parameters. If the
15 fluorescence detector is working improperly, the meter's internal error detection mechanisms will detect a problem (no signal or erratic signal) and display an error code. If the meter's stage is at the incorrect temperature, the deviant pattern of pixel switching on the electronic strip emulator
20 causes the meter to output an answer outside of the expected parameters. The user can either be instructed to not use the system when this happens, and or the meter can itself examine the results, and automatically lock itself into a "safe" mode to prevent outputting an erroneous answer when a real sample
25 is used.

Experimental Examples

 The device constructed according to the preferred embodiment disclosed above was constructed. A fluorescent
30 backing was provided by first mixing 50 mg/ml of Rhodamine-123 in 10 ml of isopropyl alcohol solution, to produce a 5 mg/ml Rhodamine-123 solution. This was mixed in a 1:3 ratio with "Clear Gloss" acrylic finish (lot 404100, Floquil-Pollt S Color Corp., Amsterdam N.Y.) The Rhodamine dye mixed evenly
35 with this acrylic paint. 10 microliters of this acrylic paint-dye mix was then applied to the back of a Polytronics liquid crystal shutter, and allowed to air dry. When dry, the paint formed a clear durable finish encapsulating the

Rhodamine-dye. After drying, the back of the liquid crystal shutter was further coated with black epoxy, forming a more durable, and light opaque fluorescence backing.

The verification device was then programmed as described above for the preferred embodiment, and tested in a
5 prototype Avocet PT-1000 prothrombin time instrument. The instrument responded to the verification device as it would to a normal test strip reacting with sample, and produced appropriate Level I (normal prothrombin time) and appropriate
10 Level II (prolonged prothrombin time) answers.

All references (including appendices, books, articles, papers, patents, and patent applications) cited herein are hereby expressly incorporated by reference in their
15 entirety for all purposes.

While the invention has been described in connection with specific embodiments thereof, it will be understood that
20 it is capable of further modification, and this application is intended to cover any variations, uses, or adaptations of the invention following, in general, the principles of the invention and including such departures from the present
25 disclosure as come within known or customary practice in the art to which the invention pertains and as may be applied to the essential features hereinbefore set forth, and as fall within the scope of the invention and the limits of the appended claims.

WHAT IS CLAIMED IS:

1 1. An electronically controlled optical reference
2 device useful for the verification of a clinical analytical
3 system having an optical detection apparatus, the reference
4 device comprising:
5 an opaque optical reference;
6 an optical shutter;
7 means for controlling the percent exposure of the
8 optical reference to the optical detection apparatus;
9 optionally, a means to monitor the temperature of a
10 reaction stage of the clinical analytical system; and
11 an algorithm or method that controls the rate at
12 which the optical reference is selectively revealed to the
13 optical detection apparatus, said algorithm or method being
14 selected as to simulate the reaction rates of one or more
1 levels of clinical analytes reacting with a test reagent.

1 2. The device of claim 1, wherein the opaque
2 optical reference simulates a colorimetric, fluorescent, or
3 luminescent reagent test strip.

1 3. The device of claim 1, further comprising one
2 or more first electrodes, wherein electrodes contact one or
3 more second electrodes on a reaction stage of the clinical
4 analytical system.

1 4. The device of claim 3, wherein electrical
2 resistance across the electrodes in the reference device is
3 modulated to simulate the addition or removal of a disposable
4 reagent test strip or cartridge to the clinical analytical
5 system.

1 5. The device of claim 3 wherein electrical
2 resistance across the electrodes in the device is modulated to
3 simulate the addition of a liquid sample to the clinical
4 analytical system.

1 6. The device of claim 1 wherein the optical
2 shutter is electronically operated.

1 7. The device of claim 1, in which the optical
2 shutter is a liquid crystal shutter, a magneto-optical
3 shutter, a Faraday effect optical shutter, a thermochromic
4 optical shutter, an electrochromic optical shutter, or a
5 micro-mechanical optical shutter.

1 8. The device of claim 1, in which the optical
2 shutter is divided into a plurality of independently or
3 semi-independently controlled pixel elements, such that the
4 optical shutter modulates the intensity of an optical signal
5 by varying the optical state of the shutter pixels in a time
6 dependent manner.

1 9. The device of claim 1, wherein the optical
2 shutter comprises a fluorescent backing on one side of the
3 optical shutter, and a first optical signal of a first
4 wavelength passes through the optical shutter and interacts
5 with the fluorescence backing, and a fluorescence signal of a
6 second wavelength passes back through the optical shutter.

1 10. The device of claim 1, wherein the optical
2 shutter comprises a colored backing on one side of the optical
3 shutter, and a first optical signal consisting of a first
4 spectrum of wavelengths passes through the optical shutter and
5 interacts with the colored backing, and a second optical
6 signal consisting of a subset of the first spectrum of
7 wavelengths passes back through the optical shutter.

1 11. The device of claim 1, wherein the optical
2 shutter comprises a luminescent backing on one side of the
3 optical shutter, and the optical signal comprises a time
4 increasing or time decreasing luminescence signal.

1 12. The device of claim 1, wherein the means for
2 monitoring the temperature of the reaction stage is a
3 thermocouple.

1 13. The device of claim 12, wherein transparency of
2 the optical shutter is modulated as a function of time and of
3 a thermocouple monitored temperature of the reaction stage,
4 wherein a range of levels of enzymatic activity measured by
5 the analytical system at various operating temperatures is
6 simulated.

7 14. The device of claim 1, further comprising means
8 to monitor the a reagent present and/or blood present sensor
9 on the clinical analytical device, wherein a stimulus to these
10 sensors is provided to signal readiness of the meter for
11 testing a clinical sample.

1 15. The device of claim 1, wherein the test reagent
2 is thromboplastin.

1 16. A verification device useful for determining
2 the proper function of an optical, temperature controlled
3 analytical instrument, the device comprising:

4 an electronic optical shutter with an optically
5 active backing, interposed between an optical signal emitted
6 by the analytical instrument and an optical detector mounted
7 on the analytical instrument;

8 a temperature sensor, the sensor contacting a
9 reaction stage on the analytical instrument; and

10 verification device electrodes, the verification
11 device electrodes making contact with electrodes on the
12 reaction stage of the analytical instrument;

13 wherein the action of the device is initiated by a
14 resistance drop across the verification device electrodes, and
15 wherein the optical transmission of the optical shutter is
16 modulated as a function of time and of the temperature of

17 the reaction stage, wherein a range of levels of enzymatic
18 activity measured by the analytical instrument at various
19 operating temperatures is simulated.

20 17. The verification device of claim 16, wherein
21 the reaction stage is heated.

1 18. A verification device useful for determining
2 the proper function of an optical, temperature controlled
3 analytical instrument, the device comprising:

4 an optical shutter-fluorescent backing assembly
5 comprising an optical shutter having a fluorescent backing
6 placed on one side of the optical shutter; the assembly being
7 interposed between an optical signal emitted by the analytical
8 instrument and an optical detector mounted on the analytical
9 instrument;

10 a thermocouple in contact with a reaction stage on
11 the analytical instrument; and

12 verification device electrodes, the verification
13 device electrodes making contact with electrodes on the
14 reaction stage of the analytical instrument;

15 wherein the action of the device is initiated by a
16 resistance drop across the device electrode, and wherein the
17 fluorescence of the optical shutter-fluorescent backing
18 assembly is modulated as a function of time and of the
19 temperature of the reaction stage, wherein a range of levels
20 of enzymatic activity measured by the analytical instrument at
21 various operating temperatures is simulated.

22 19. The verification device of claim 18, wherein
23 the reaction stage is heated.

1 20. An electronically controlled optical reference
2 device, useful for the verification of an analytical
3 instrument having an optical detection apparatus and using
4 optically read reagent test strips, the device comprising:

5 an opaque optical reference, which simulates the
6 optical characteristics of a reagent test strip after reaction
7 with its intended clinical sample;

8 an optical shutter;
9 a means for controlling the percent exposure of the
10 optical reference to the optical detection apparatus; and
11 an algorithm or method that controls the rate at
12 which the check strip is selectively revealed to the optical
13 detection apparatus, said algorithm or method being selected
14 as to mimic the reaction rates of one or more levels of
15 clinical analytes reacting with a reagent test strip.

16 21. The device of claim 20, wherein the reagent is
17 thromboplastin.

1 22. A method for verifying the correct performance
2 of a clinical analytical system comprising an optical
3 detection apparatus, the method comprising:

4 contacting the clinical analytical system with
5 an electronically controlled optical reference device useful
6 for the verification of clinical devices using optically read
7 reagent test strips, the reference device comprising, an
8 opaque optical reference, which simulates the optical
9 characteristics of a reagent test strip after reaction with
10 its intended clinical sample;

11 an optical shutter;
12 means for controlling the percent exposure of the
13 optical reference to the optical detection apparatus;

14 optionally, a means to monitor the temperature of
15 the clinical analytical system; and

16 an algorithm or method that controls the rate at
17 which the optical reference is selectively revealed to the
18 optical device, said algorithm or method being selected as to
19 mimic the reaction rates of one or more levels of clinical
20 analytes reacting with a reagent test strip; and

21 analyzing the optical reference; wherein an expected
22 result of analysis of the optical reference by the clinical
23 analytical system is predictive of the correct performance of
24 the clinical analytical system.

1 23. A method for verifying the temperature control
2 of a clinical analytical system comprising an optical
3 detection apparatus, the method comprising:
4 contacting the clinical analytical system with a
5 verification device useful for determining the proper function
6 of an optical, temperature controlled analytical instrument,
7 the device comprising:
8 an electronic optical shutter with an optically
9 active backing, interposed between an optical signal emitted
10 by the analytical instrument and an optical detector mounted
11 on the enzymatic analytical instrument;
12 a temperature sensor, the sensor contacting a
13 reaction chamber on the analytical instrument; and
14 verification device electrodes, the verification
15 device electrodes making contact with electrodes on the
16 reaction chamber of the analytical instrument;
17 wherein the action of the device is initiated by a
18 resistance drop across the verification device electrodes, and
19 wherein the optical transmission of the optical shutter is
20 modulated as a function of time and of the temperature of the
21 reaction chamber, wherein a range of levels of enzymatic
22 activity measured by the analytical instrument at a range of
23 operating temperatures is simulated, and
24 analyzing the optical reference;
25 wherein an expected result of analysis of the
26 optical reference by the clinical analytical system is
27 predictive of the correct operating temperature of the
28 reaction chamber of the clinical analytical system.

1 24. A method for verifying the output of a system
2 having a radiation source and a radiation detector, said
3 method comprising:
4 positioning a reference surface to receive
5 radiation from the radiation source and return radiation to
6 the detector; and
7 modulating at least one of the radiation from
8 the source and the radiation to the detector over time to
9 emulate reflective or radiation characteristics of a chemical
10 or biological reaction on the reference surface.

1 25. A method for verifying the output of a system
2 having a radiation source and a radiation detector, said
3 method comprising:
4 positioning a reference surface to receive
5 radiation from the radiation source and return radiation to
6 the detector; and
7 modulating at least one of the radiation from
8 the source and the radiation to the detector over time in
9 response to temperature changes.

1 26. A method as in claim 25, wherein the
2 temperature changes are determined within the system.

1 27. A method as in claim 26, wherein the
2 temperature changes are determined external to the system.

1 28. Apparatus for use in combination with an
2 analyzer having a radiation source and a radiation detector,
3 said apparatus comprising:
4 a reference surface which produces return
5 radiation in response to receiving radiation from the source,
6 and
7 means disposed adjacent the radiation surface
8 for modulating at least one of radiation to the reference
9 surface or radiation from the reference surface.

1 29. Apparatus as in claim 28, wherein the
2 modulating means modulates the radiation over time to emulate
3 reflective or radiation characteristics of a chemical or
4 biological reaction on the reference surface.

1 30. Apparatus as in claim 28 or 29, wherein the
2 modulation means modulates the radiation in response to
3 changes in temperature.

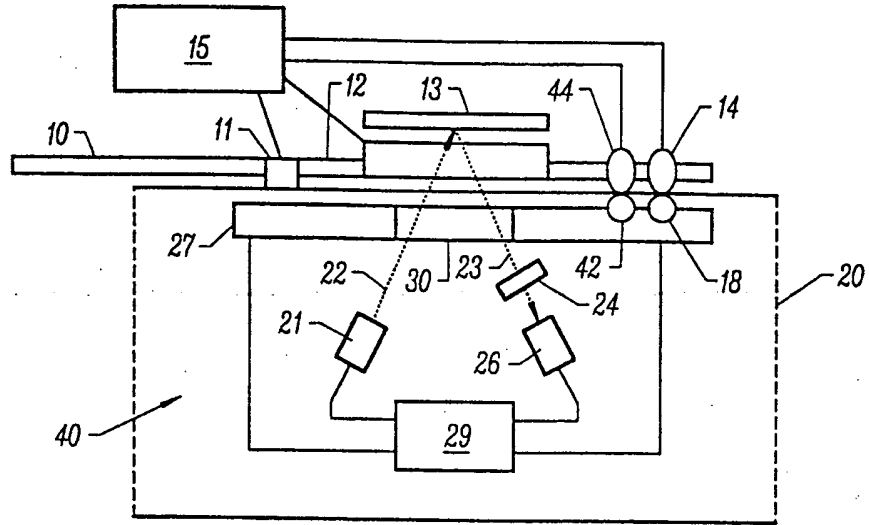

FIG. 1

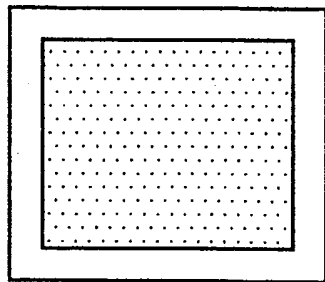

FIG. 2A

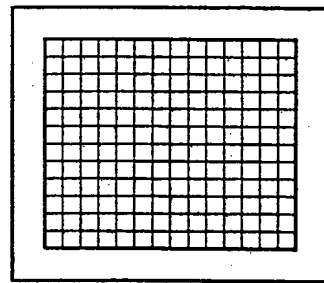

FIG. 2B

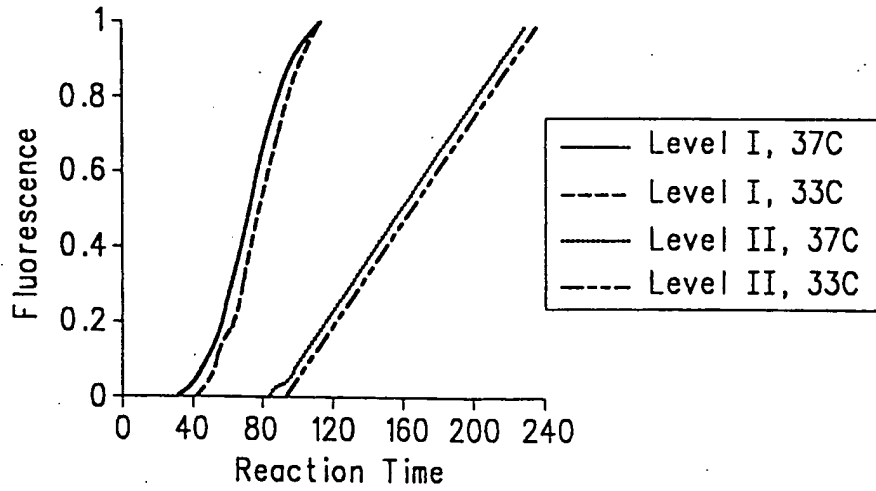

FIG. 3

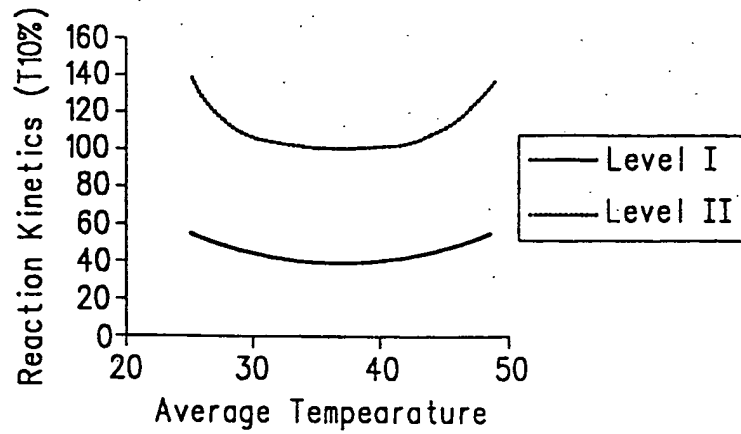

FIG. 4

INTERNATIONAL SEARCH REPORT

International application No.
PCT/US98/17947

A. CLASSIFICATION OF SUBJECT MATTER IPC(6) :GO1J 1/02; A61B 5/00; GO1D 18/00 US CL :Please See Extra Sheet. According to International Patent Classification (IPC) or to both national classification and IPC		
B. FIELDS SEARCHED Minimum documentation searched (classification system followed by classification symbols) U.S. : 356/243.1, 243.5, 446; 250/252.1; 422/82.05, 57, 58, 68; 436/46,48 Documentation searched other than minimum documentation to the extent that such documents are included in the fields searched NONE Electronic data base consulted during the international search (name of data base and, where practicable, search terms used) APS search terms: calibration, shutter, color, simulation, temperature		
C. DOCUMENTS CONSIDERED TO BE RELEVANT		
Category*	Citation of document, with indication, where appropriate, of the relevant passages	Relevant to claim No.
X	US 5,030,005 A (SWOPE et al.) 9 Jul 1991 (09/07/91), see entire document.	1-30
A	US 5,284,770 A (ADRIAN et al.) 8 Feb 1994 (08/02/94), see entire document.	1-30
A	US 5,348,005 (MERRICK et al.) 20 Sept 1994 (20/09/94), see entire document.	1-30
<input type="checkbox"/> Further documents are listed in the continuation of Box C. <input type="checkbox"/> See patent family annex.		
* Special categories of cited documents: "A" document defining the general state of the art which is not considered to be of particular relevance "E" earlier document published on or after the international filing date "L" document which may throw doubts on priority claim(s) or which is cited to establish the publication date of another citation or other special reason (as specified) "O" document referring to an oral disclosure, use, exhibition or other means "P" document published prior to the international filing date but later than the priority date claimed	"T" later document published after the international filing date or priority date and not in conflict with the application but cited to understand the principle or theory underlying the invention "X" document of particular relevance; the claimed invention cannot be considered novel or cannot be considered to involve an inventive step when the document is taken alone "Y" document of particular relevance; the claimed invention cannot be considered to involve an inventive step when the document is combined with one or more other such documents, such combination being obvious to a person skilled in the art "&" document member of the same patent family	
Date of the actual completion of the international search 21 OCTOBER 1998		Date of mailing of the international search report 24 DEC 1998
Name and mailing address of the ISA/US Commissioner of Patents and Trademarks Box PCT Washington, D.C. 20231 Facsimile No. (703) 305-3230		Authorized officer: <i>Zandra V. Smith</i> ZANDRA V. SMITH Telephone No. (703) 305-7776

INTERNATIONAL SEARCH REPORT

International application No.
PCT/US98/17947

A. CLASSIFICATION OF SUBJECT MATTER:

US CL :

356/243.1, 243.5, 446; 250/252.1; 422/82.05, 57, 58, 68; 436/46,48

This Page Blank (uspto)

**This Page is Inserted by IFW Indexing and Scanning
Operations and is not part of the Official Record**

BEST AVAILABLE IMAGES

Defective images within this document are accurate representations of the original documents submitted by the applicant.

Defects in the images include but are not limited to the items checked:

- BLACK BORDERS**
- IMAGE CUT OFF AT TOP, BOTTOM OR SIDES**
- FADED TEXT OR DRAWING**
- BLURRED OR ILLEGIBLE TEXT OR DRAWING**
- SKEWED/SLANTED IMAGES**
- COLOR OR BLACK AND WHITE PHOTOGRAPHS**
- GRAY SCALE DOCUMENTS**
- LINES OR MARKS ON ORIGINAL DOCUMENT**
- REFERENCE(S) OR EXHIBIT(S) SUBMITTED ARE POOR QUALITY**
- OTHER:** _____

IMAGES ARE BEST AVAILABLE COPY.

As rescanning these documents will not correct the image problems checked, please do not report these problems to the IFW Image Problem Mailbox.

This Page Blank (uspto)